

Link Controls Ltd.

Stuart Road, Manor Park, Runcorn, WA7 1TS

Tel: +44(0)1928 579050

www.link-controls.co.uk

Fax: +44(0)1928 579259

sales@link-controls.co.uk

CDO-100kb

Braked Rolling Door Operator

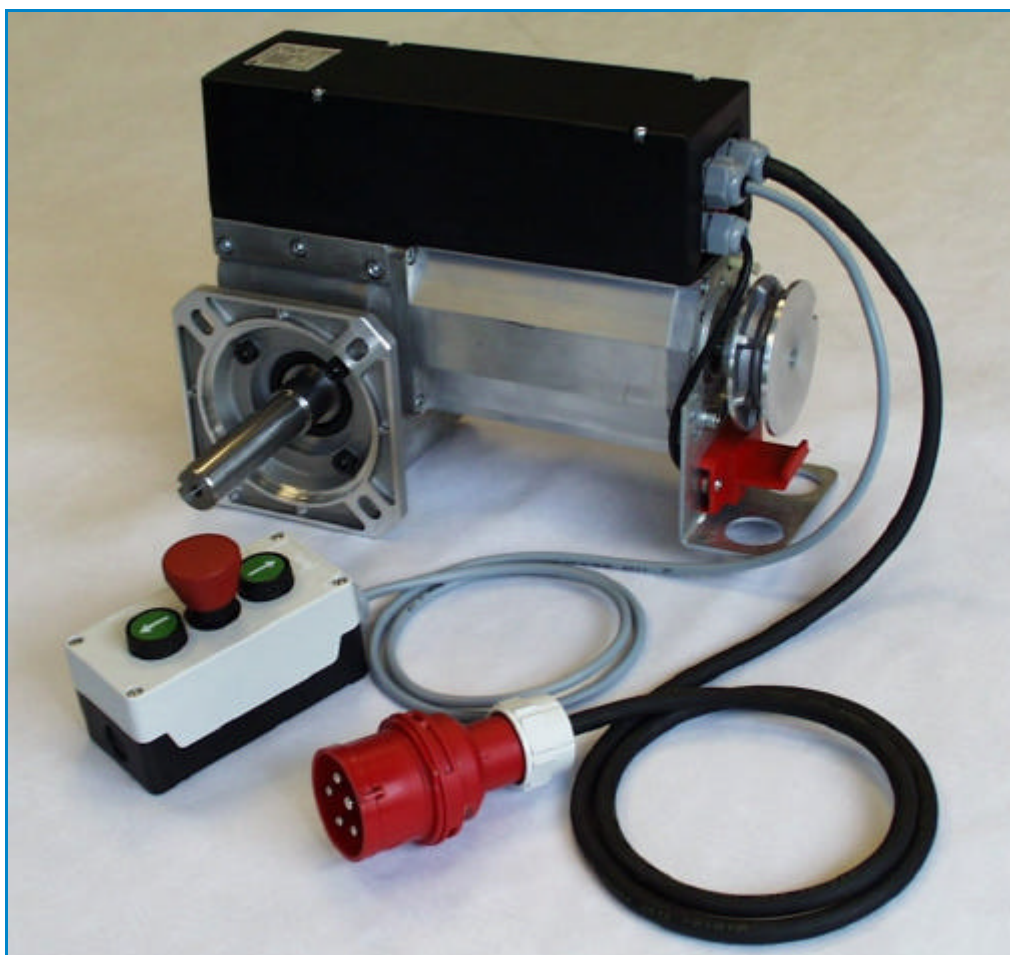

Special Features:

- * Integral Brake
- * Available with pre-wired starter or Mini Standard Starter
- * Available with a variety of manual operating systems
- * Safety Interlock Switch for manual operation
- * Handing can be changed on site to suit the installation
- * Developed to make installation easy and simple
- * Integral Thermal Protection
- * IP 54 Environment Protection
- * Gear driven Limit Switches
- * Phosphor bronze Worm Wheel

Product Description

The CDO-100kb Rolling Door Operator has a 0.55kW, 400V Three Phase Motor. These models are available with Hand Crank, Floor Level Hand Chain & High Level Hand Chain Systems, which enables the roller shutter door to be manually opened & closed when required.

TECHNICAL INFORMATION

Data \ Type	CDO-100kb c/w Hand Crank	CDO-100kb c/w Floor Level Hand Chain	CDO-100kb c/w High Level hand Chain
<i>Power (kW)</i>	0.55		
<i>Torque (Nm)</i>	120 / 85 / 60		
<i>Output Speed (R.P.M.)</i>	22 / 30 / 45		
<i>Number of Turns</i>	33		
<i>IP Rating</i>	54		
<i>Current (Amps)</i>	1.8		
<i>Power Supply</i>	400V/3ph/50Hz		

DIMENSIONS: CDO-100kb 3ph c/w High Level Hand Chain

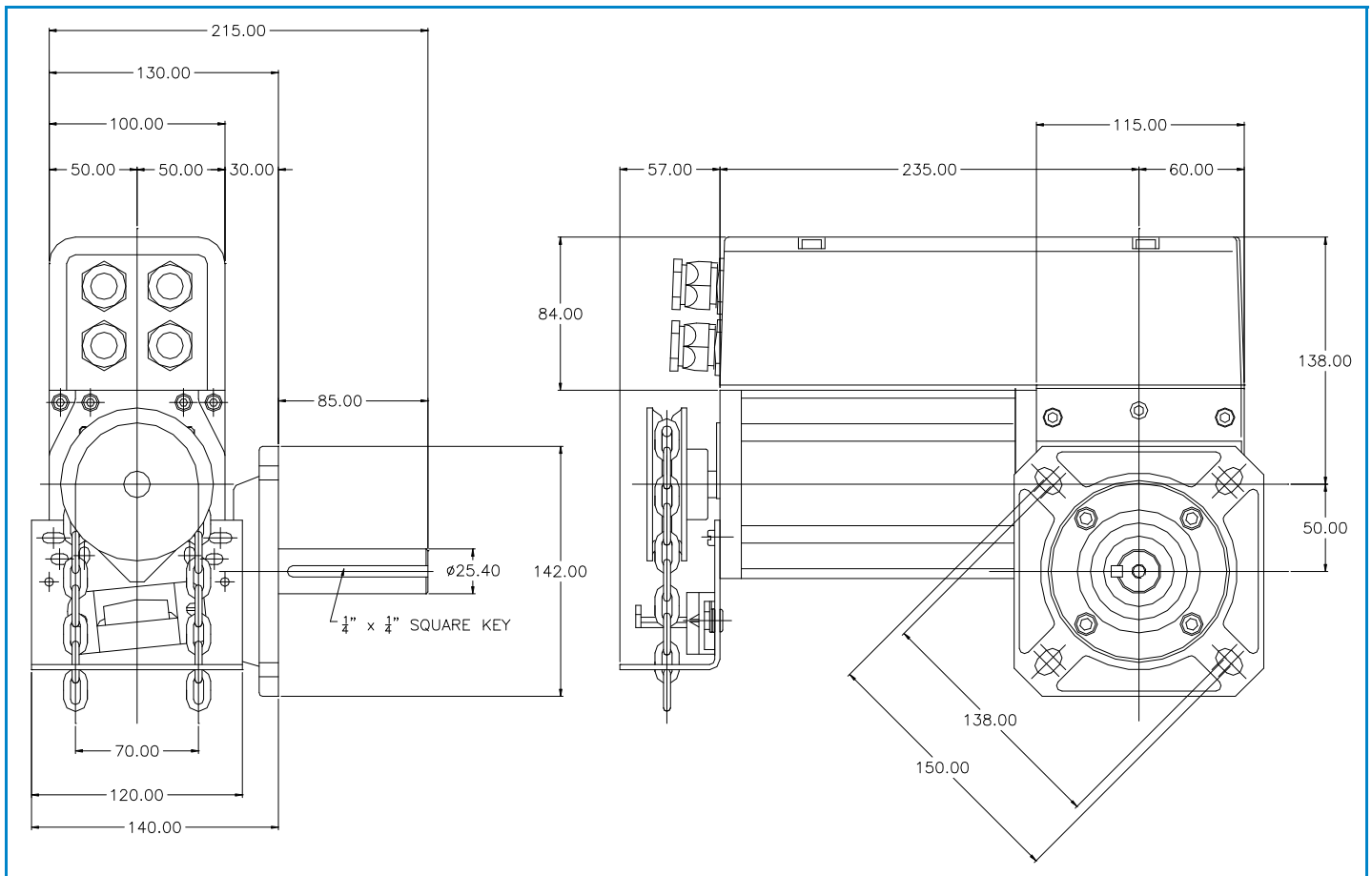

Dimension drawings of other types are available on request