

Link Controls Ltd.

Stuart Road, Manor Park, Runcorn, WA7 1TS

Tel: +44(0)1928 579050

www.link-controls.co.uk

Fax: +44(0)1928 579259

sales@link-controls.co.uk

CDO-50

Hazardous Area Equipment

-Suitable For Zone 1 and 2, IIB, T4 Rated Area

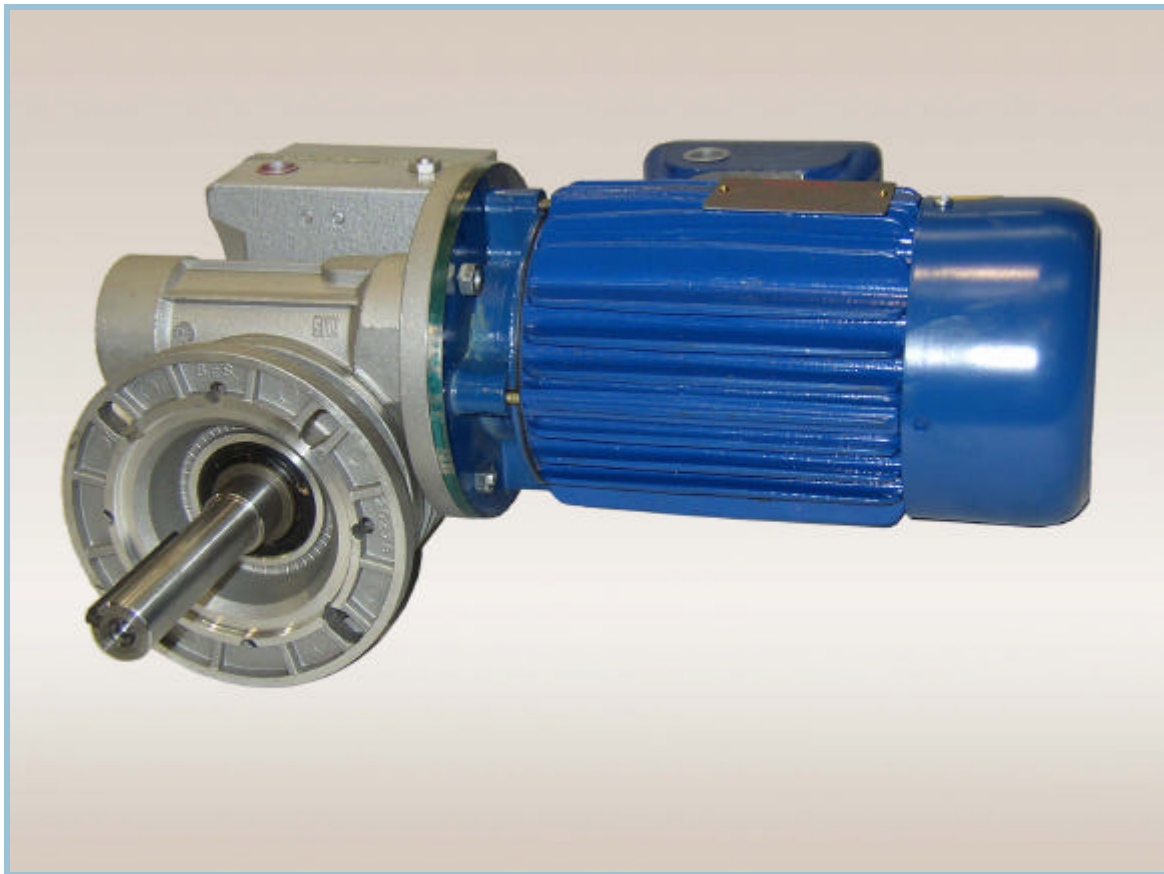

Special Features

- * I.P. 54 Environment Protection
- * Phosphor Bronze Worm Wheel
- * High Starting Torque - Industrial Duty Motor
- * Explosion Proof Motor
- * Industry standard 1" Shaft
- * Also IIC, T4 Available on Request
- * Handcrank Operation

PRODUCT DESCRIPTION

The CDO-50 Explosion Proof Operator is available in 0.37 kw power size with 400v Three Phase Explosion Proof motor. This model uses an industrial duty motor and hence provides high starting torque. It is also fitted with a industry standard 1" shaft which enables to use conventional driving accessories.

TECHNICAL INFORMATION & ORDER CODES

Data \ Type	CDO-50
Power (kW)	0.37
Output Speed (R.P.M.)	31
Environmental Protection	I.P.54
Current (Amps)	1.1
Power Supply	400v/3ph/50Hz
Order Code	21-0302

OPERATOR DIMENSIONS

TYPE:- CDO-50 c/w Shaft and Key

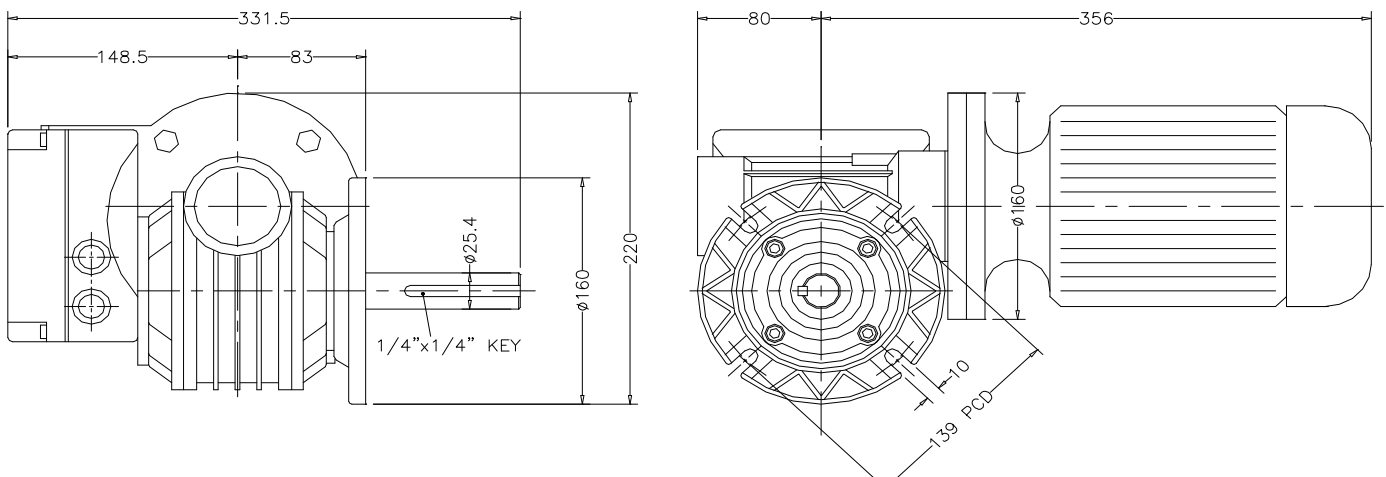

Link Controls Limited
INDUSTRIAL DOOR AND GATE OPERATORS
ACCESS CONTROL & SECURITY EQUIPMENT

Stuart Road, Manor Park, Runcorn WA7 1TS
Tel: 01928 579050 Fax: 01928 579259
Email: sales@link-controls.co.uk
Web: www.link-controls.co.uk